



RAIL SYSTEM SRA400

The SRA400 is the rail system specially designed for the large and therefore **heavy cooling or refrigeration cells**. The SRA250 rail serves as a base, by using a solid aluminium tread and a heavier motor the carrying capacity has increased to no less than **400 kg**. The fall-lifting system in combination with our sealing rubbers provides an **excellent seal** with wall or doorframe. The rail is fully assembled to the customer's specifications and is easy to install.

Materials

- Made of anodised aluminium
- Stainless steel fasteners
- Plastic castors for feather-light and silent operation
- Solid aluminium tread

Properties

- Fall-lift system
- Side suspension
- Various types of brackets suitable for mounting directly on the wall or in combination with doorframe
- Lightweight, compact and sleek design
- Low maintenance
- Easy to assemble
- Equipped with derailing failure protection
- Easy to (dis)assemble finishing cover
- Available as a bi-parting door

Electrically operated

- The motor is integrated in the finishing cap
- Easy programming with instructions on backlit display
- Manuals, wiring diagrams and instructional videos available at www.doorcontrol.eu
- In accordance with CE directives
- 120v and UL certified versions available
- Available with electric motor lock
- Powered by toothed belt
- Two configurable potential-free contacts
- Suitable for wireless control and components

Production and development

- Developed in-house
- The R&D department can develop distinctive customer specific products
- Made to made
- Short delivery time
- Mounting instructions included and available at www.gaspack.nl/en

Accessories

- Inner and outer door handles
- Floor guidance
- Safety components such as photocells, radar and light curtains
- Push buttons, locks, pull switches and remote controls

In addition to fully assembled rail systems we also supply various complementary rubber seals, frame and door profiles made to measure or in various trade lengths. With the right sawing installation, sufficient working space and skilled technicians, you can also assemble the rail, door or doorframe yourself.



Easy To Install

SPECIFICATIONS RAIL SYSTEM SRA400

- Maximum carrying capacity of 400 kg
- Door widths from 650 to 5500 mm
- Minimum door thickness is 80 mm

Manually operated

Width: door width * 2 + 300 mm

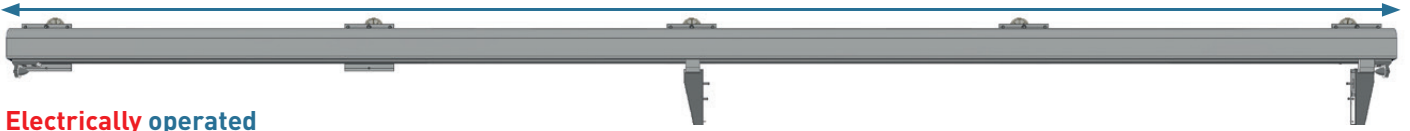

Electrically operated

Width: door width * 2 + 505 mm

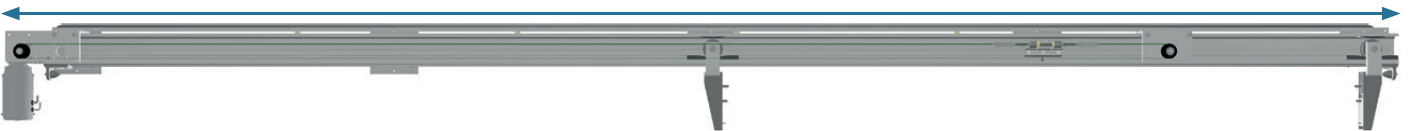

Manually operated

Height: 140 mm

Depth: 145 mm (flat bracket)

175 mm (120 mm bracket)

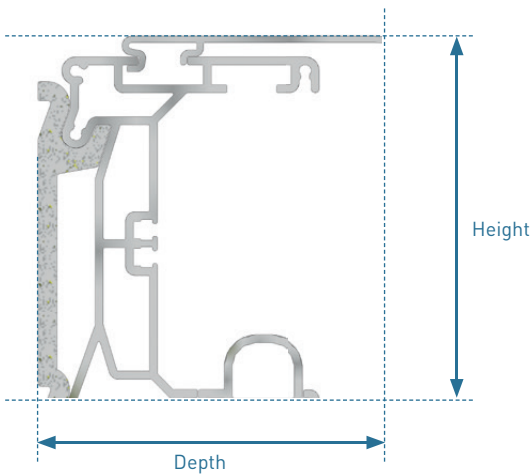

Electrically operated

Height: 220 mm

Depth: 210 mm (flat bracket)

240 mm (120 mm bracket)

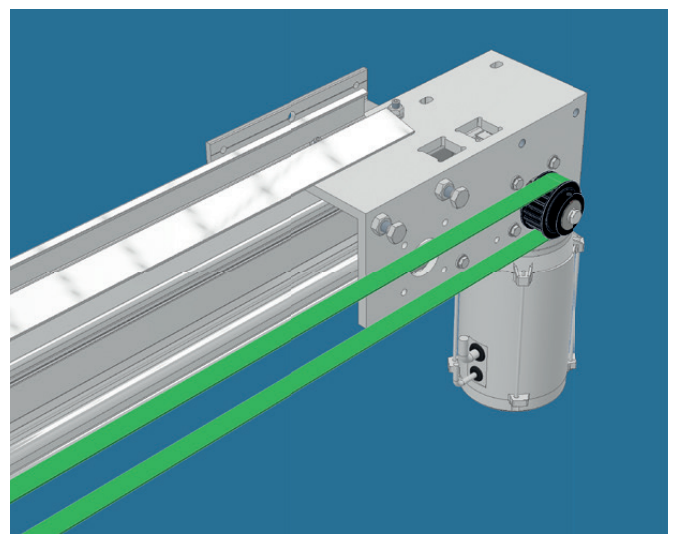
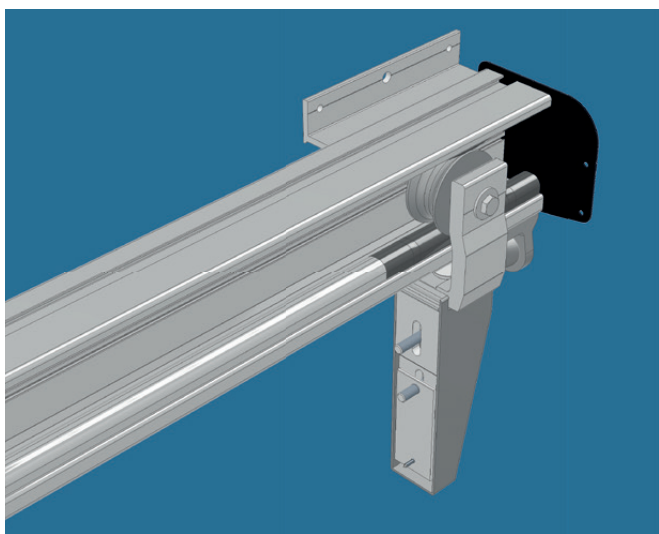
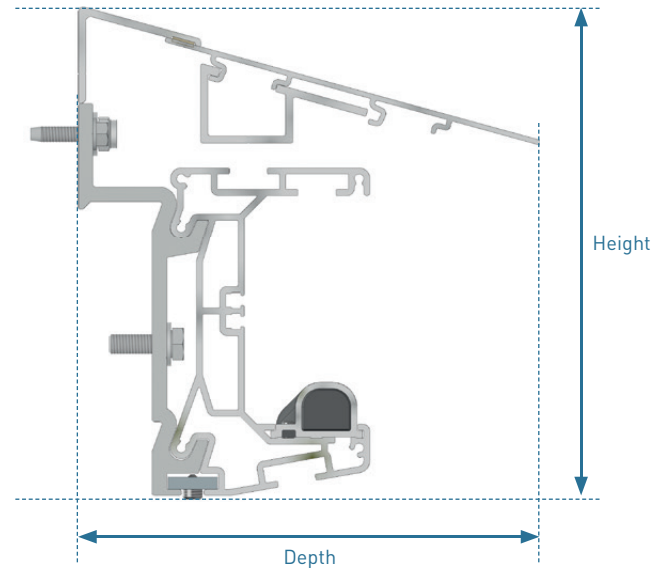

+31 (0) 229 - 26 74 57 INFO@GASPACK.NL

Nieuwmarkt 2, 1681 NP Zwaagdijk-Oost, The Netherlands