

Montagehandleiding:
Aluminium valhefrailsysteem handbediend <400Kg

Installation manual :
Aluminium drop/lift rail system manually operated <400Kg

Montageanleitung:
Aluminium Fallhebe Schienensystem handbedient <400Kg

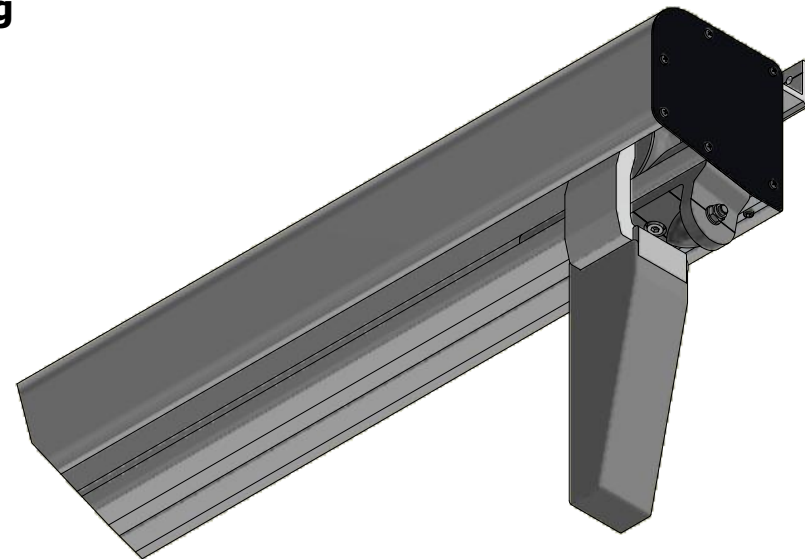

Railopbouw / Rail construction / Schienenaufbau

Dekstuk 200mm
Outer frame 200mm
Rahmen 200mm

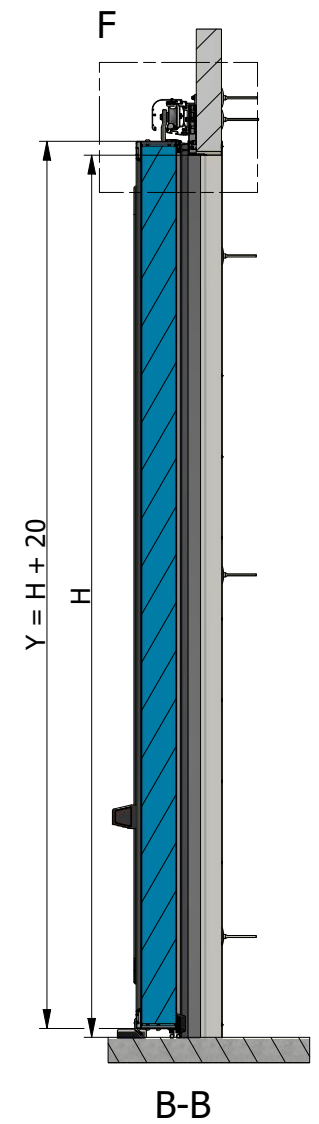
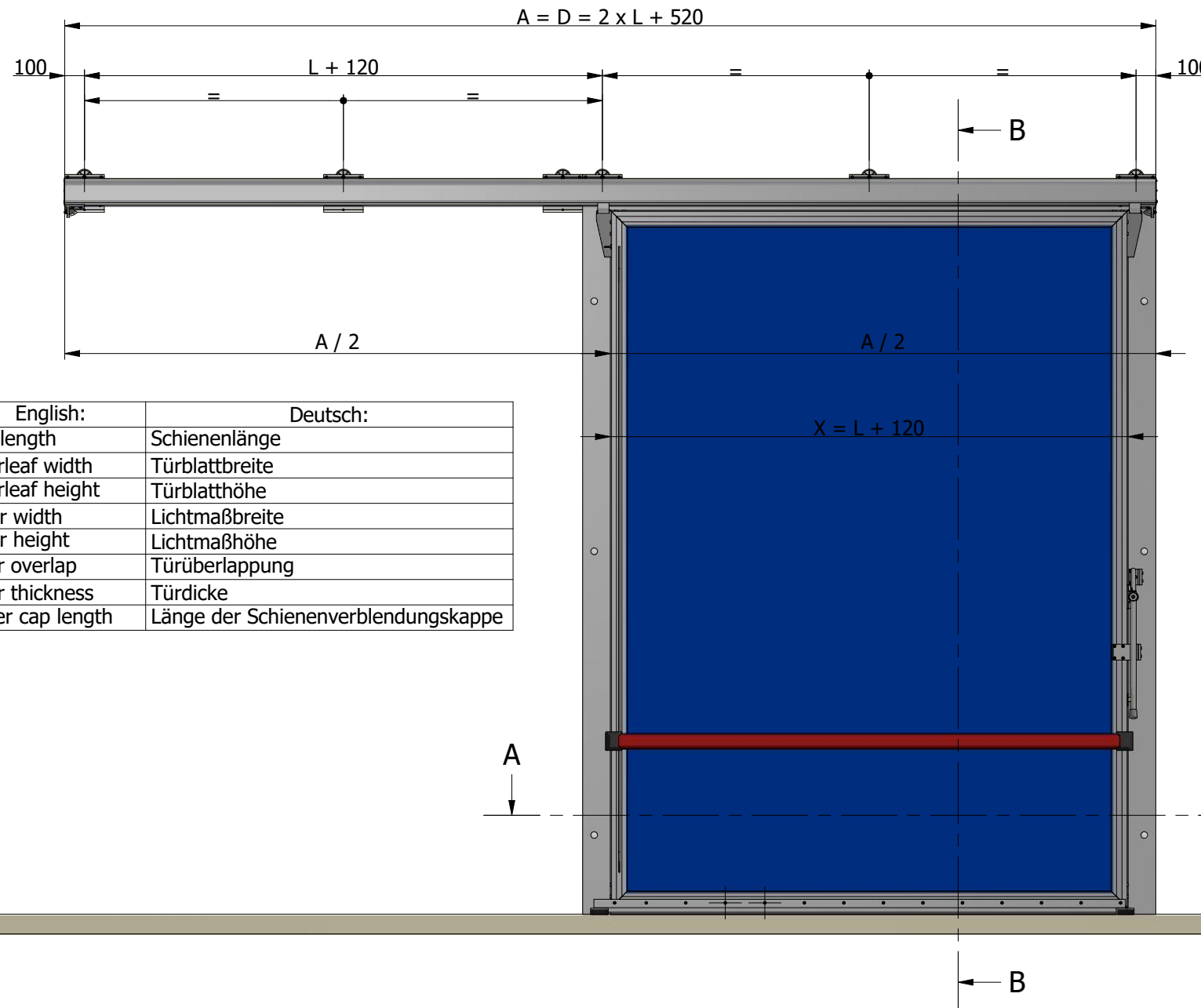
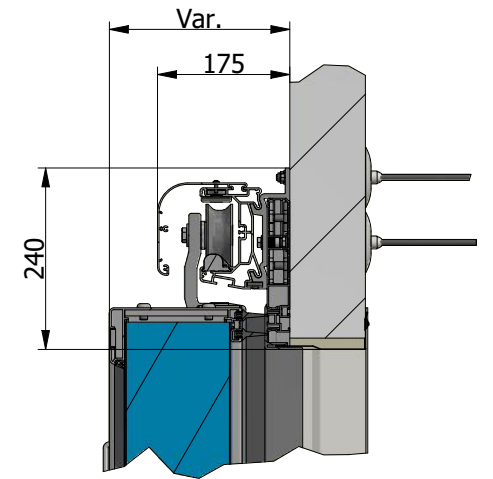
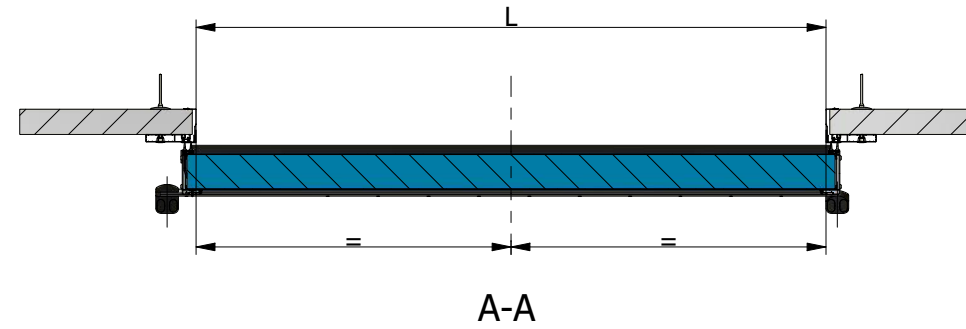

	Nederlands:	English:	Deutsch:
A	Raillengte	Rail length	Schiene n länge
X	Bladbreedte	Doorleaf width	Türblattbreite
Y	Bladhoogte	Doorleaf height	Türblatthöhe
L	Dagbreedte	Clear width	Lichtmaßbreite
H	Daghoogte	Clear height	Lichtmaßhöhe
R	Deuroverlap	Door overlap	Türüberlappung
E	Deurdikte	Door thickness	Türdicke
D	Lengte afwerkkap	Cover cap length	Länge der Schienenverblendungskappe

Ruwheid NEN 3634	Maattolerantie NEN-ISO-406		Vorm en plaatstol. NEN-ISO-1101
Amerikaanse projectie 	Schaal : Maateenheid: mm	Getekend : AGR Datum : 5-6-2019	Tekeningnummer : SRA350-MON-11001
Benaming : railopbouw HB-200			Nummer: 1 Van : 1
			Formaat: A3

Railopbouw / Rail construction / Schienenaufbau

Dekstuk 120mm
Outer frame 120mm
Rahmen 120mm

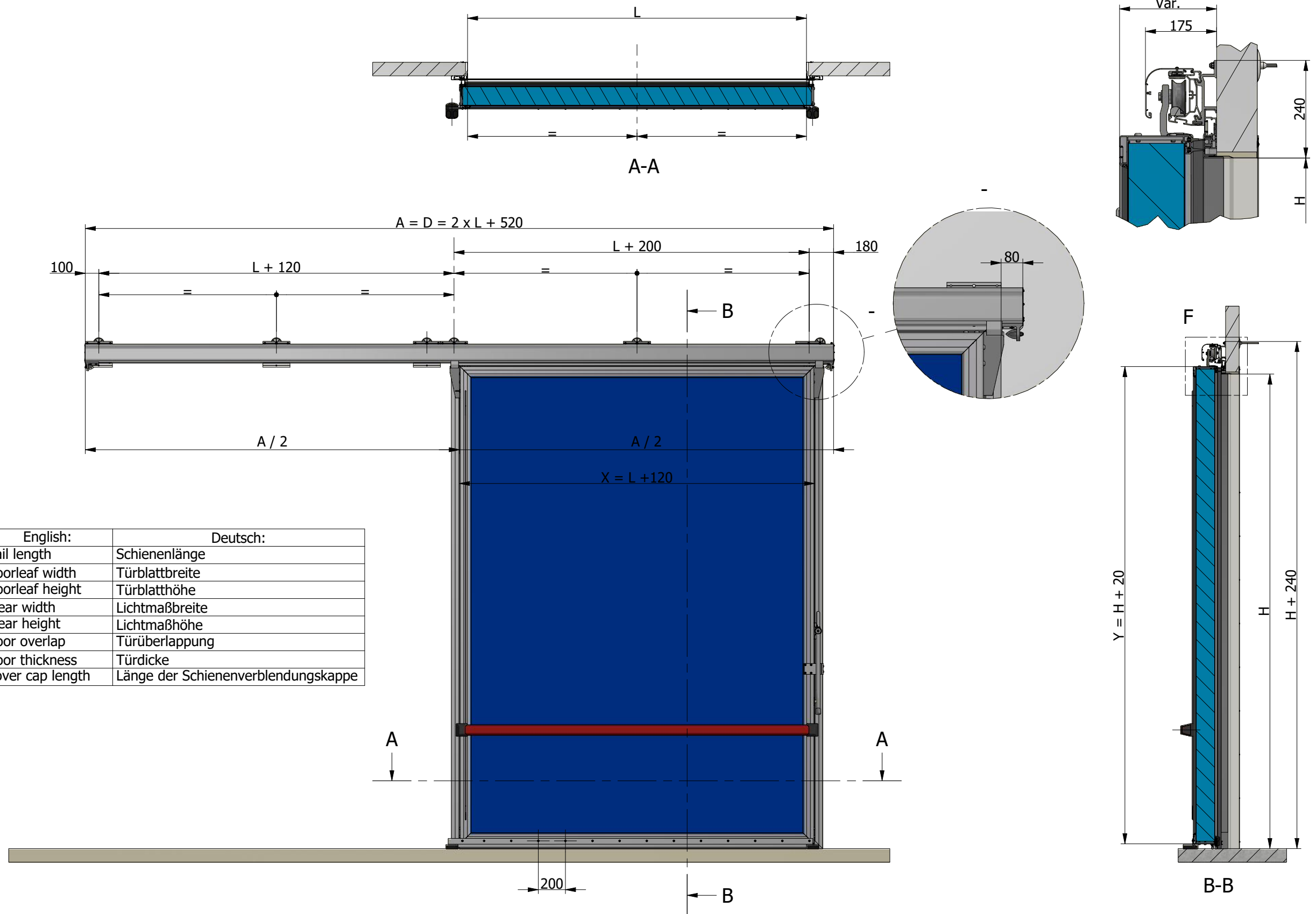

	Nederlands:	English:	Deutsch:
A	Raillengte	Rail length	Schiene n länge
X	Bladbreedte	Doorleaf width	Türblattbreite
Y	Bladhoogte	Doorleaf height	Türblatthöhe
L	Dagbreedte	Clear width	Lichtmaßbreite
H	Daghoogte	Clear height	Lichtmaßhöhe
R	Deuroverlap	Door overlap	Türüberlappung
E	Deurdikte	Door thickness	Türdicke
D	Lengte afwerkkap	Cover cap length	Länge der Schienenverblendungskappe

Ruwheid NEN 3634	Maattolerantie NEN-ISO-406		Vorm en plaatstol. NEN-ISO-1101
Amerikaanse projectie 	Schaal : Maateenheid: mm	Getekend : AGR Datum : 2-5-2019	Tekeningnummer : SRA350-MON-21001
Benaming : railopbouw HB-120			Nummer: 1 Van : 1
			Formaat: A3

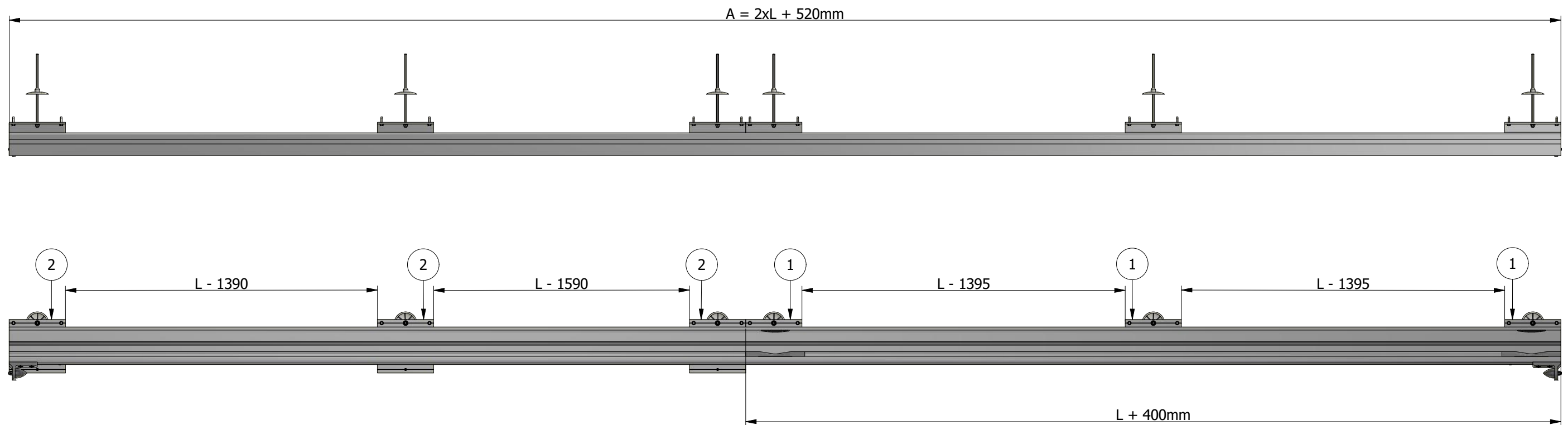

	Nederlands:	English:	Deutsch:
A	Raillengte	Rail length	Schiene n länge
X	Bladbreedte	Doorleaf width	Türblattbreite
Y	Bladhoogte	Doorleaf height	Türblatthöhe
L	Dagbreedte	Clear width	Lichtmaßbreite
H	Daghoogte	Clear height	Lichtmaßhöhe
R	Deuroverlap	Door overlap	Türüberlappung
E	Deurdikte	Door thickness	Türdicke
D	Lengte afwerkkap	Cover cap length	Länge der Schienenverblendungskappe

2	3	SRA250 bracket excl. dekst. L= 200mm	A-73450-00
1	3	SRA250 bracket op 200mm dekst. L= 200mm	A-73440-00
Pos	Aantal	Omschrijving	Artikelnummer
Ruwheid NEN 3634	Maattolerantie NEN-ISO-406	Vorm en plaatstol. NEN-ISO-1101	
Amerikaanse projectie 	Schaal : Maateenheid: mm	Getekend : AGR Datum : 5-6-2019	Tekeningnummer : SRA350-MON-11012
Benaming : Verdeling brackets SRA350HB			Nummer: 1 Van : 1
			Formaat: A3

Loopvlak / Lauffläche / Running surface

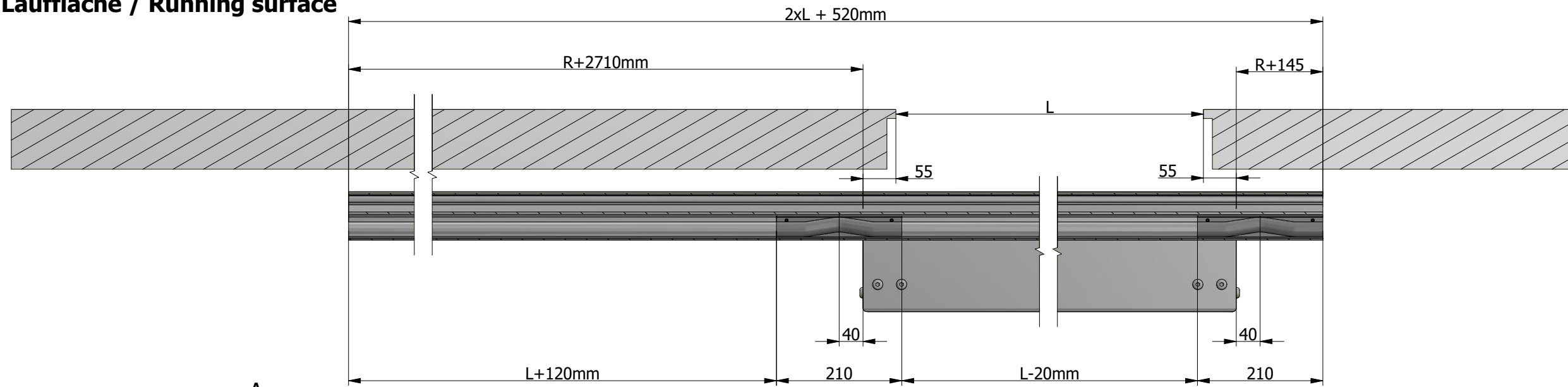

← Schuifrichting / Sliding direction / Schieberichtung

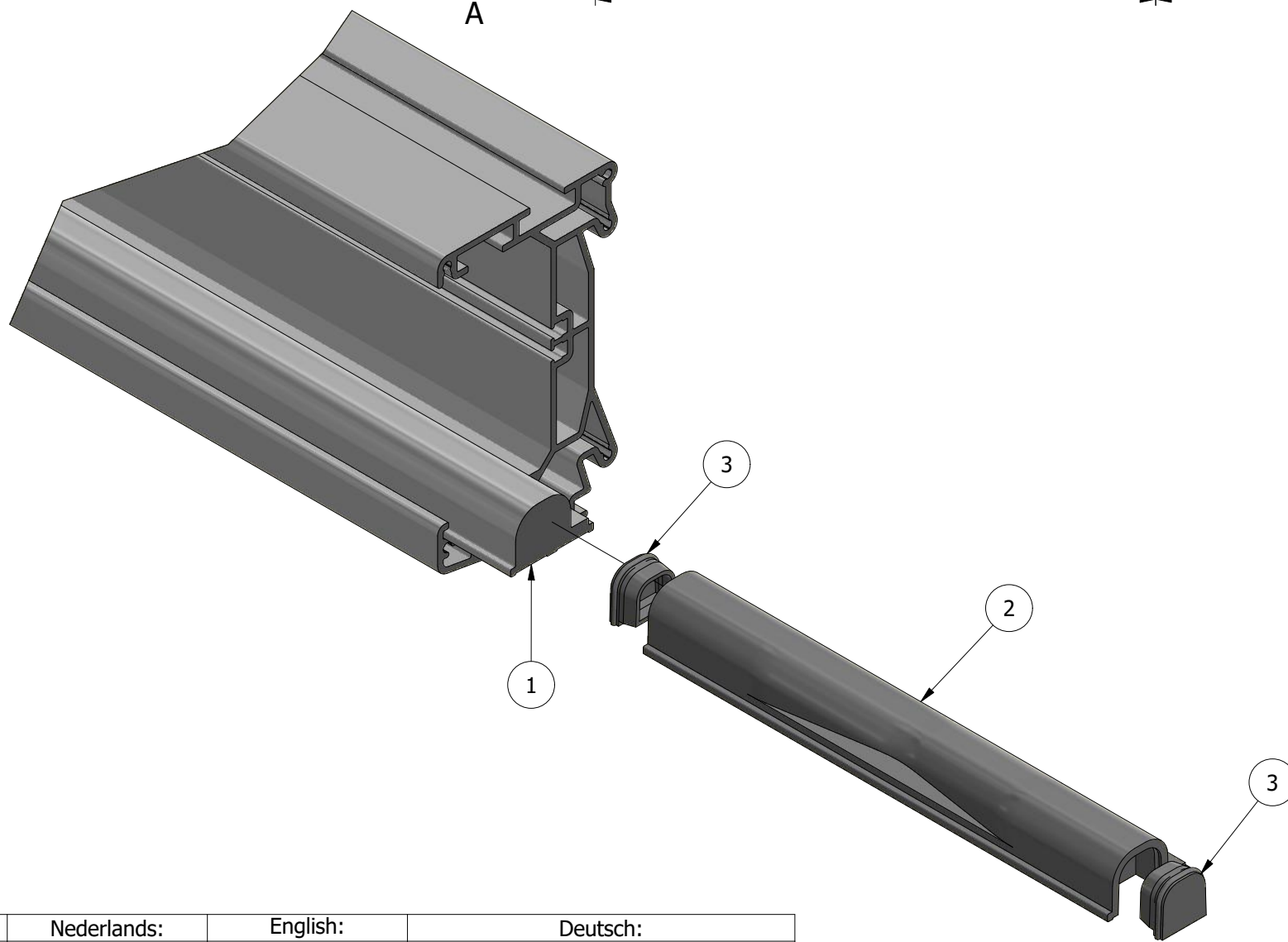

	Nederlands:	English:	Deutsch:
A	Raillengte	Rail length	Schienenlänge
X	Bladbreedte	Doorleaf width	Türblattbreite
Y	Bladhoogte	Doorleaf height	Türblatthöhe
L	Dagbreedte	Clear width	Lichtmaßbreite
H	Daghoogte	Clear height	Lichtmaßhöhe
R	Deuroverlap	Door overlap	Türüberlappung
E	Deurdikte	Door thickness	Türdicke
D	Lengte afwerkkap	Cover cap length	Länge der Schienenverblendungskappe

3	4	Couple insert plastic dent 2016		A-67786-00
2	2	SRA250 kunststof deuk loopvlak 2016		A-67785-00
1	2	SRA350 loopvlak ano L= 6000mm (massief)		A-67632-00
Pos	Aantal	Omschrijving	Maat	Artikelnummer
Ruwheid NEN 3634		Maattolerantie NEN-ISO-406	Vorm en plaatstol. NEN-ISO-1101	
Amerikaanse projectie		Schaal : Maateenheid: mm	Getekend : AGR Datum : 24-5-2019	Tekeningnummer : SRA350-MON-11002
Benaming : SRA350HB - loopvlak			Nummer: 1 Van : 1	Formaat: A3

Ophangpunt / Aufhängepunkt / Suspension point

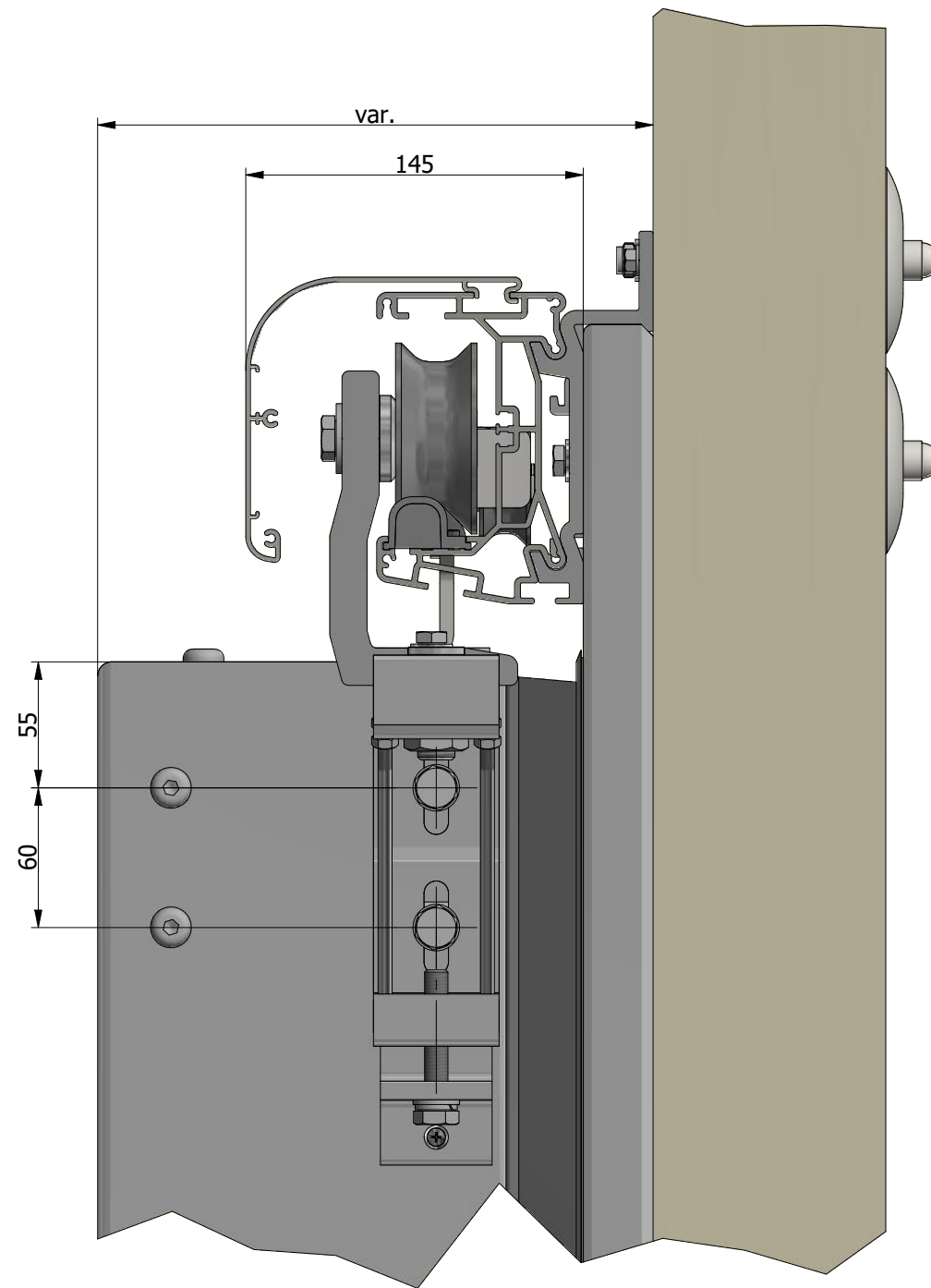

afgebeeld detail dekstuk 200mm

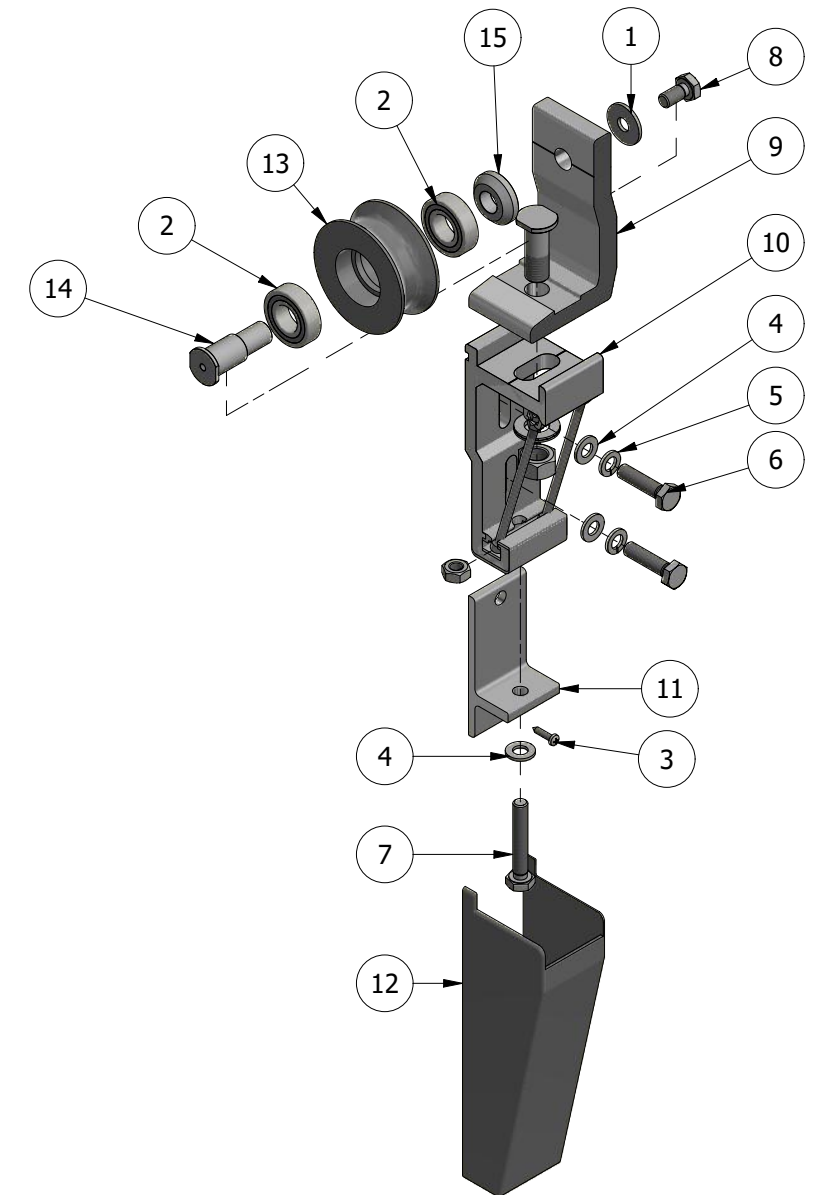

15	A-82506-00	SR alu - Ophangpunt as ring
14	A-82505-00	SR alu - Ophangpunt as
13	A-82503-00	SR alu - Looprol kunststof
12	A-82501-00	SR alu Afwerkkapje ophangpunt
11	A-73420-00	SR alu Ophangpunt deel 3
10	A-73411-00	SRA250 ophangpunt deel 2 ano L= 54.0mm
9	A-73400-00	SR alu Ophangpunt deel 1
8	A-63933-00	zeskant tapbout 10x20 vz 8.8
7	A-63889-00	zeskant tapbout 10x60 vz
6	A-63377-00	zeskant tapbout 10x40 vz 8.8
5	A-63340-00	veerring m10 vz
4	A-63338-00	onderlegging m10 vz
3	A-22075-00	zelfborende schroef 4.2x19mm ck vz
2	A-16327-00	lager 6004 llu as 20
1	A-12011-00	carrossiering M10 x 30 (a2)

Pos	Artikelnummer	Omschrijving	
Ruwheid NEN 3634	Maattolerantie NEN-ISO-406	Vorm en plaatstol. NEN-ISO-1101	
Amerikaanse projectie 	Schaal : Maateenheid: mm	Getekend : AGR Datum : 5-6-2019	Tekeningnummer : SRA350-MON-11003
Benaming : SR350HB -ophangpunt			Nummer: 1 Van : 1
			Formaat: A3

Borging rail + stootbuffer / Rail locking + buffer / Schienensicherung + Stoßpuffer

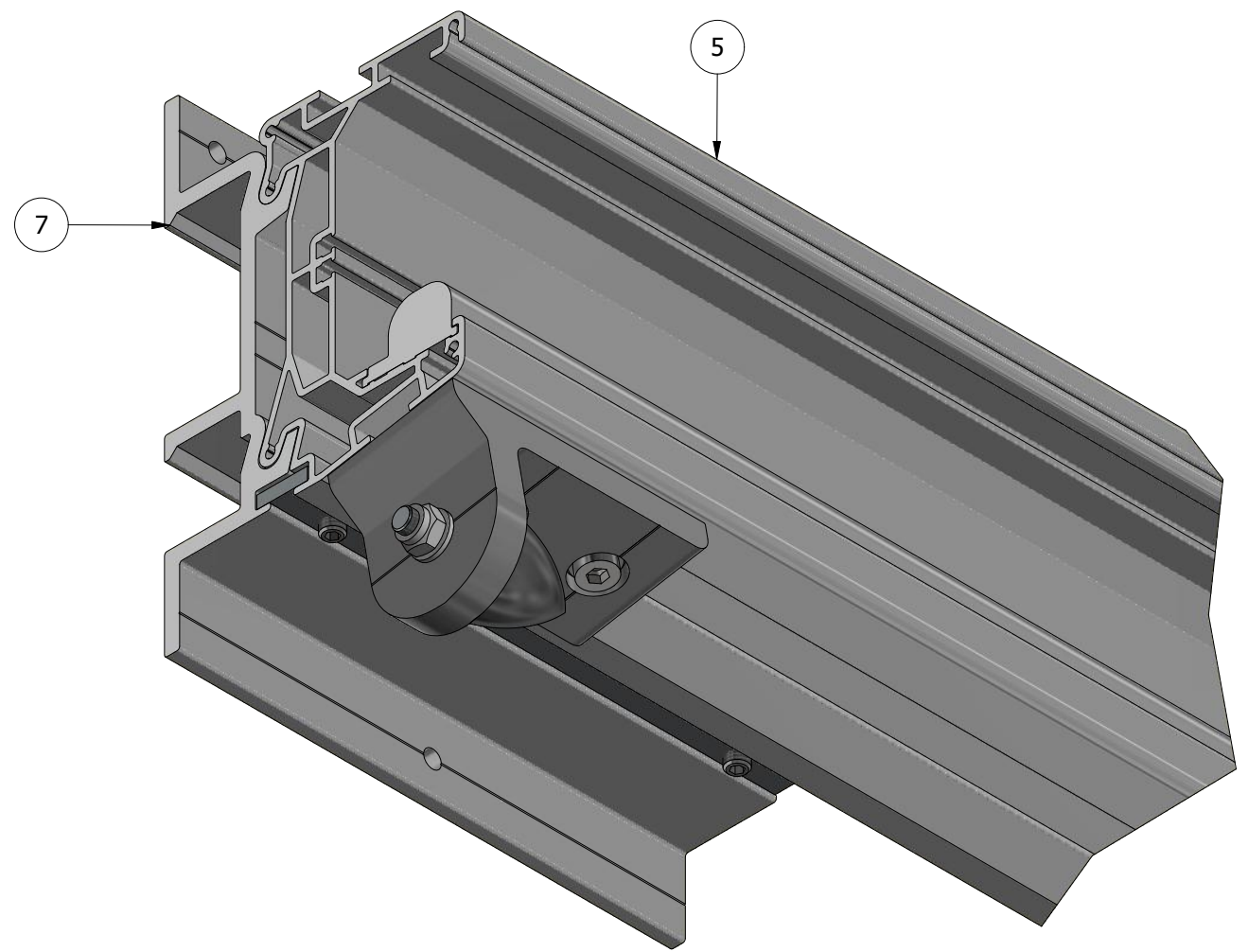
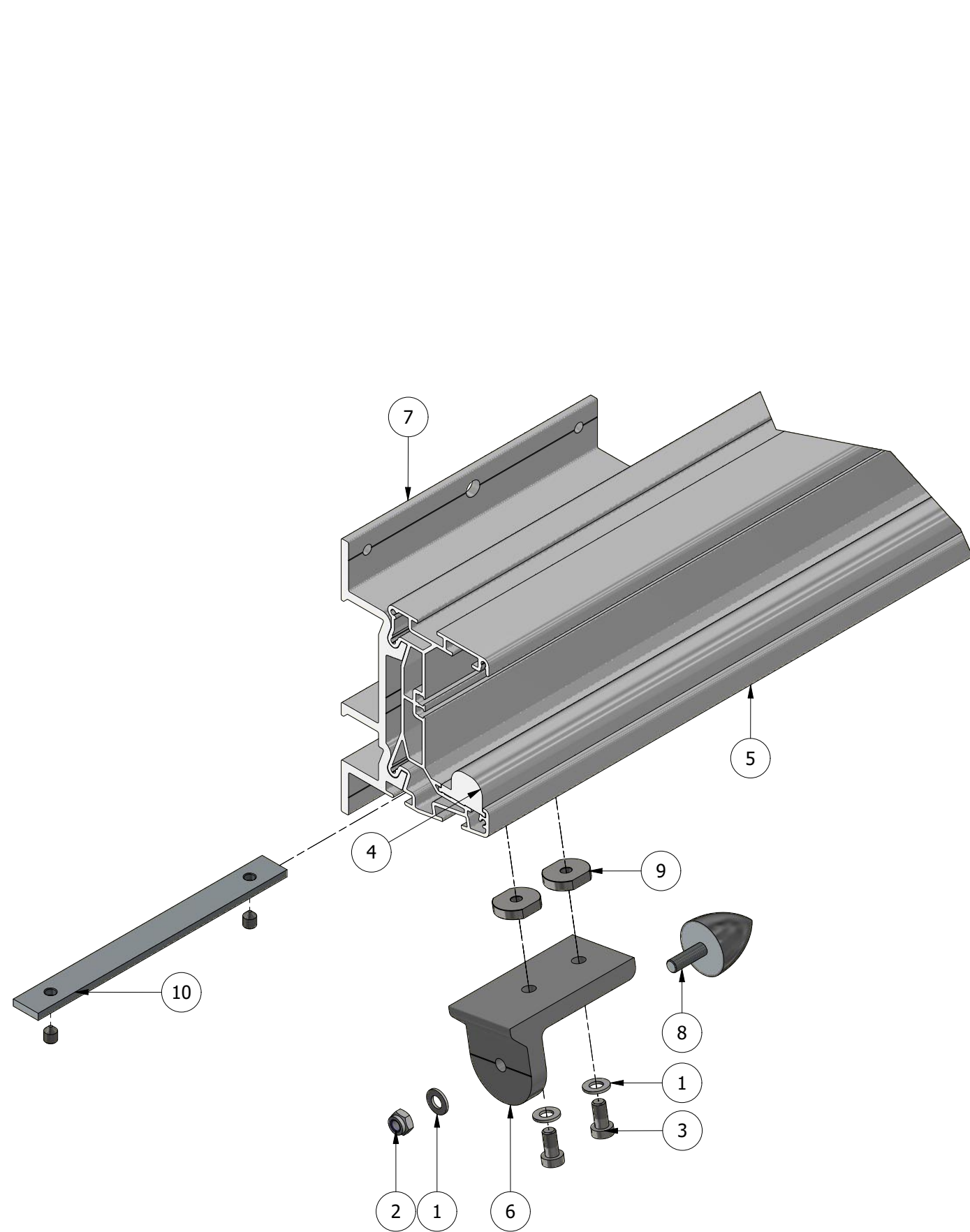

10	A-82512-00	SRA250 bracket borgstrip elvz 20x5mm
9	A-82509-00	SRA250 zeskant moer tbv rail elvz
8	A-82508-00	SRA250 stootbuffer 35x40 M8x25
7	A-73450-00	SRA250 bracket excl. dekst. L= 200mm
6	A-73430-00	SRA250 stootbuff. beugel Ral 9005 L= 50
5	A-72331-00	SRA250 rail ano L= 3250mm
4	A-67632-00	SRA350 loopvlak ano L= 6000mm (massief)
3	A-63926-00	Binnenzeskant bout M8x16 cil. vz.
2	A-63348-00	zelfborgmoer m08 vz
1	A-63337-00	onderlegging m08
Pos	Artikelnummer	Omschrijving
Ruwheid NEN 3634	Maattolerantie NEN-ISO-406	Vorm en plaatstol. NEN-ISO-1101
Amerikaanse projectie 	Schaal : Maateenheid: mm	Getekend : AGR Datum : 24-5-2019
Benaming : SR350HB - borging rail / stootbuffer		Tekeningnummer : SRA350-MON-11004
		Nummer: 1 Van : 1
		Formaat: A3

Rail deling / Rail division / Schienenteilung

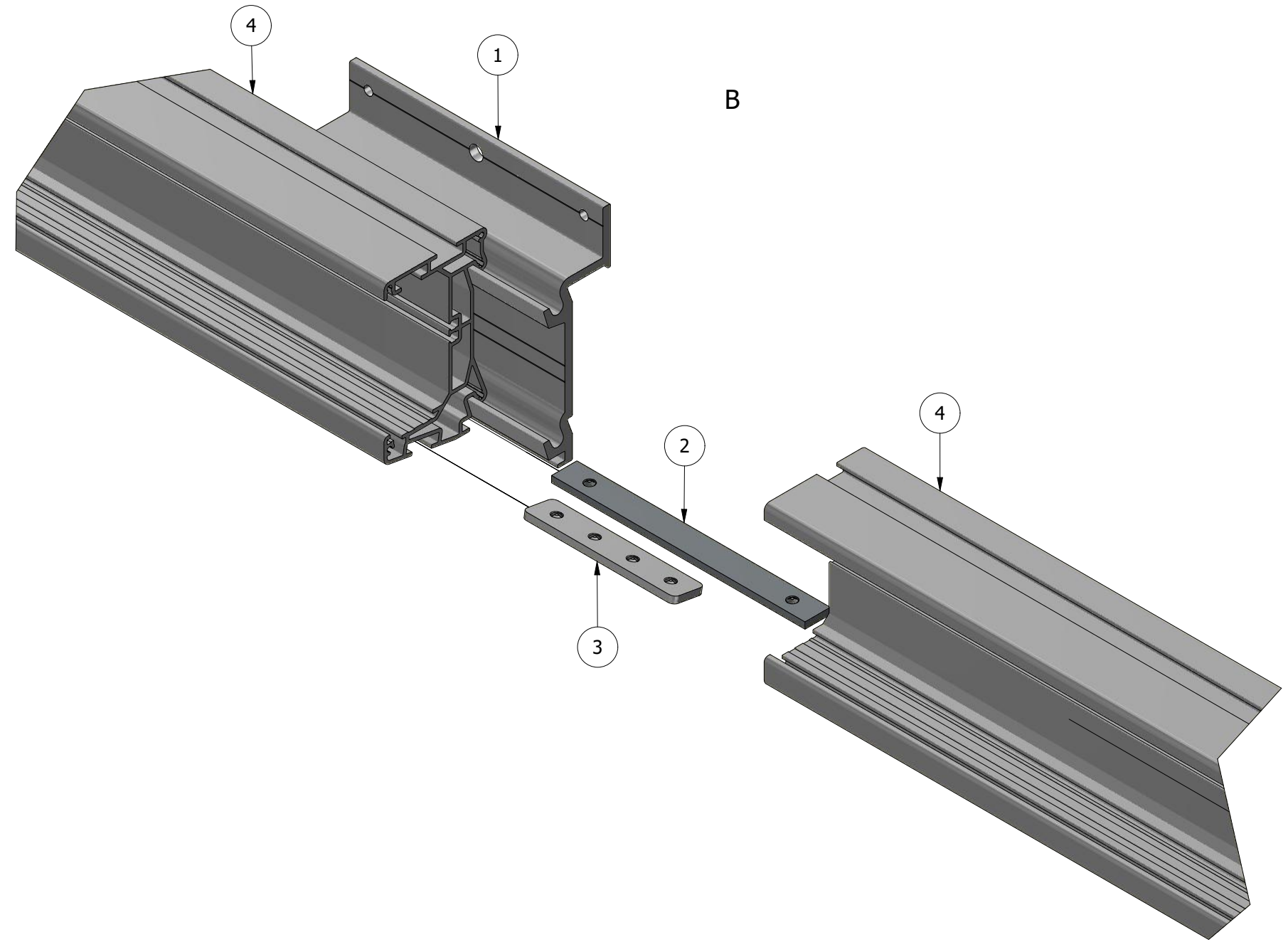
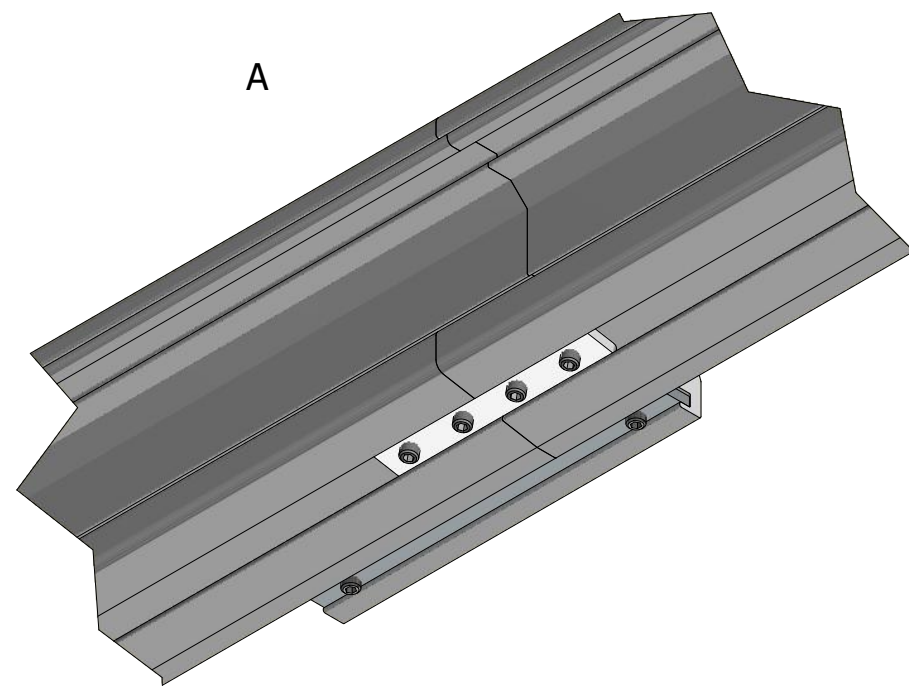

Pos	Aantal	Omschrijving	Maat	Artikelnummer
4	2	SRA250 rail ano L= 3350mm		A-72333-00
3	1	SRA250 koppelstrip gelakt		A-82552-00
2	1	samenstelling borgstrip brackets		A-82562-00
1	1	SRA250 bracket op 200mm dekst. L= 200mm		A-73440-00
Ruwheid NEN 3634		Maattolerantie NEN-ISO-406	Vorm en plaatstol. NEN-ISO-1101	
Amerikaanse projectie 		Schaal : Maateenheid: mm	Getekend : AGR Datum : 5-6-2019	Tekeningnummer : SRALU-MON-11005
Benaming : SRA350 Raildeling			Nummer: 1 Van : 1	Formaat: A3

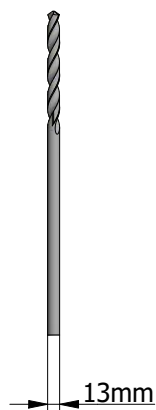
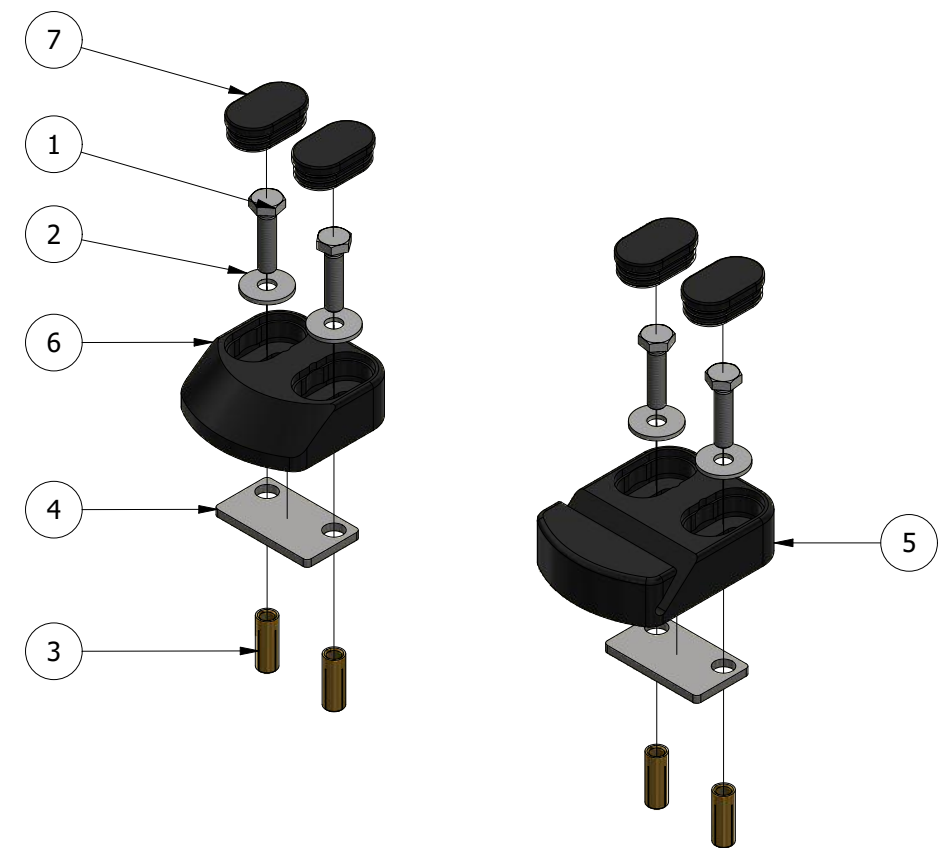
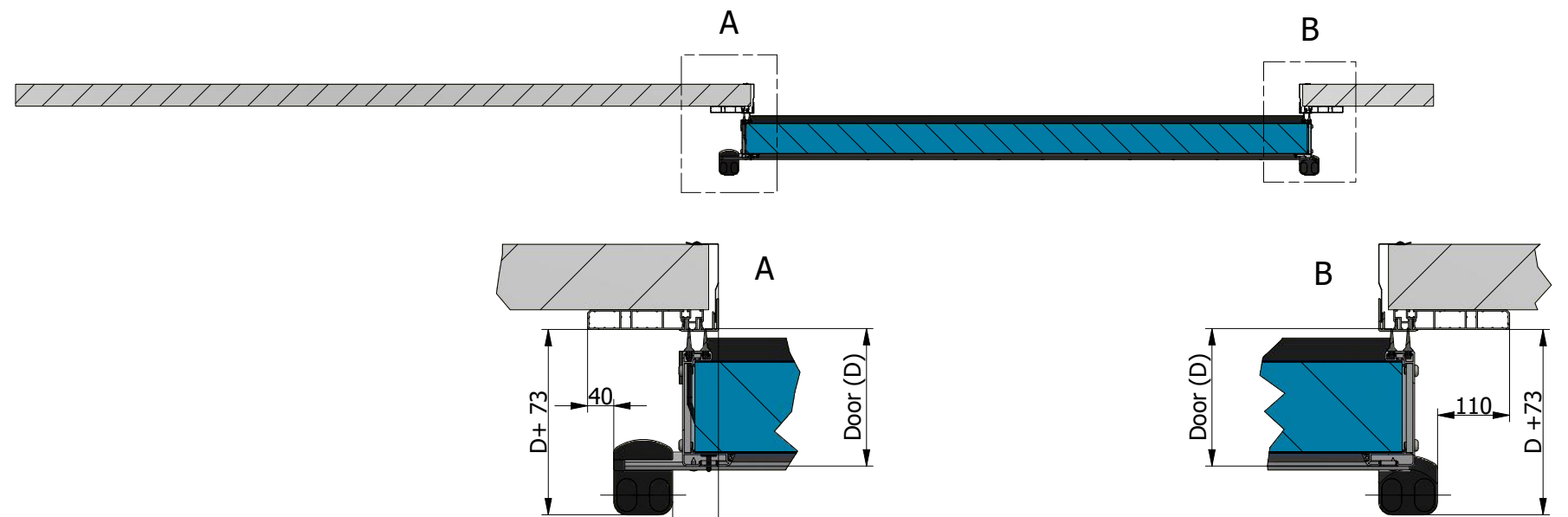
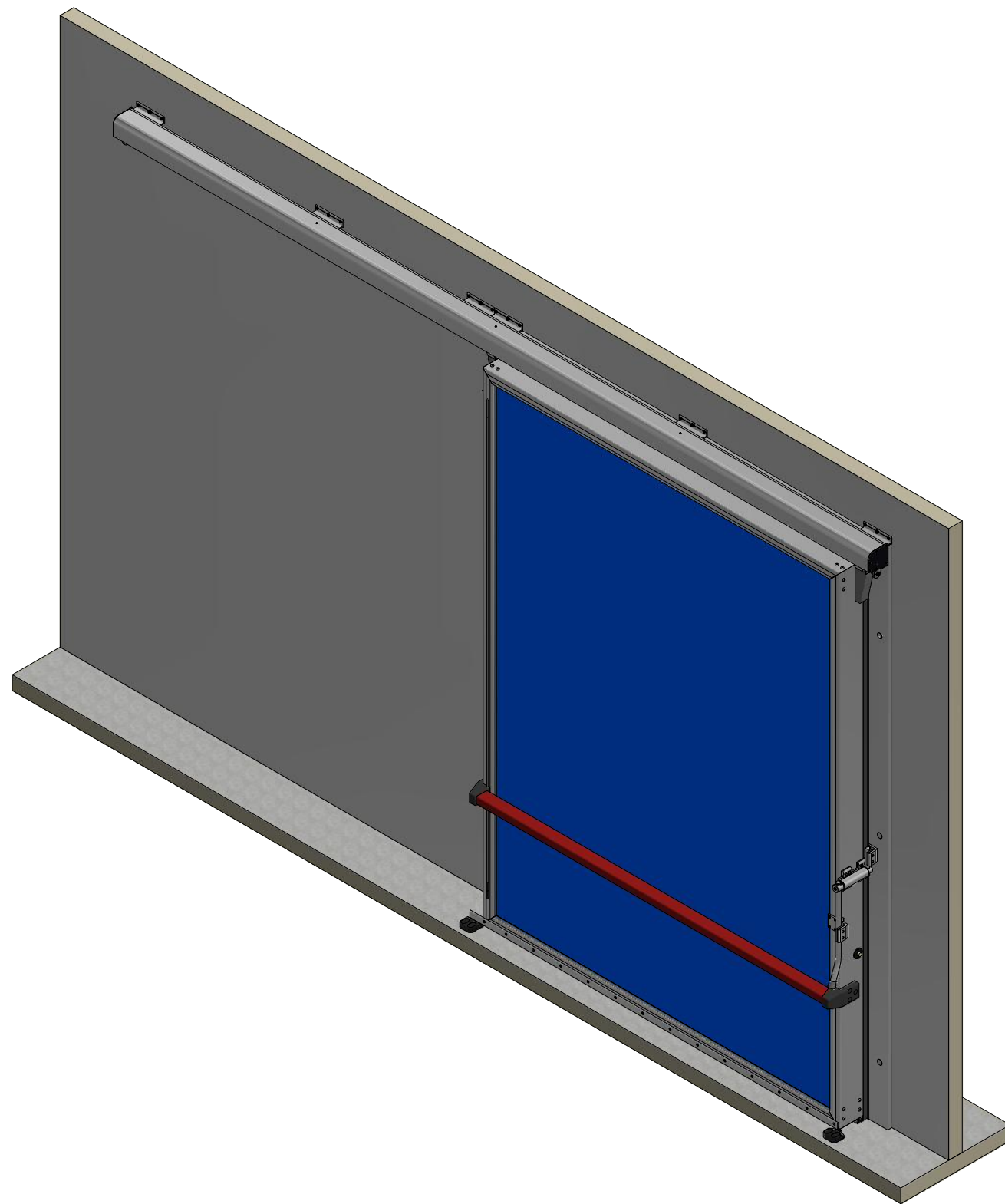

17mm
socket hex bit 17mm
Innersechskant inbus 17mm

Pos	Aantal	Omschrijving	Artikelnummer
7	4	lamellenstop ovaal 50x30mm zwart	A-67170-00
6	1	ondergeleidenok sluitzijde HMPE zwrt	A-67169-00
5	1	ondergeleidenok openzijde HMPE zwrt	A-67168-00
4	2	ondergeleidenok voetplaat	A-63256-00
3	4	messaging plug M10x34mm	A-62149-00
2	4	carroseriering M10 x 30	A-62118-00
1	4	zeskant tapbout a2 10x40	A-15009-00

Ruwheid NEN 3634	Maattolerantie NEN-ISO-406	Getekend : AGR	Vorm en plaatstol. NEN-ISO-1101
Amerikaanse projectie 	Schaal : Maateenheid: mm	Datum : 5-6-2019	Tekeningnummer : SRA350-MON-10007
Benaming : SRA350HB 200 ondergeleideblokken			Nummer: 1 Van : 1
			Formaat: A3

Uitvalbeveiliging / Drop out safety device / Ausfallschutz

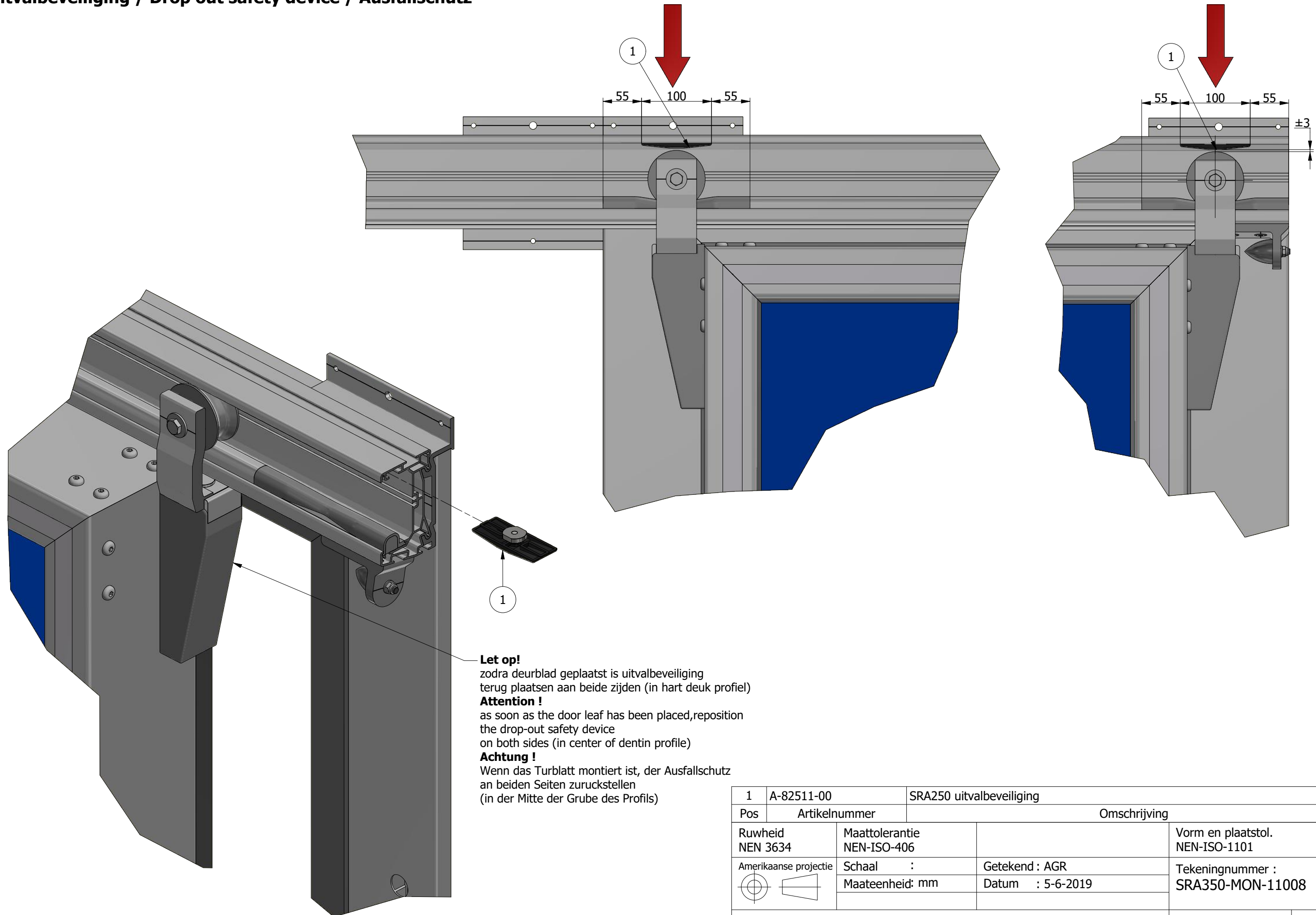

Let op!
 zodra deurblad geplaatst is uitvalbeveiliging terug plaatsen aan beide zijden (in hart deuk profiel)
Attention !
 as soon as the door leaf has been placed, reposition the drop-out safety device on both sides (in center of dentin profile)
Achtung !
 Wenn das Turblatt montiert ist, der Ausfallschutz an beiden Seiten zuruckstellen (in der Mitte der Grube des Profils)

1	A-82511-00	SRA250 uitvalbeveiliging	
Pos	Artikelnummer	Omschrijving	
Ruwheid NEN 3634	Maattolerantie NEN-ISO-406		Vorm en plaatstol. NEN-ISO-1101
Amerikaanse projectie	Schaal : Maateenheid: mm	Getekend : AGR Datum : 5-6-2019	Tekeningnummer : SRA350-MON-11008
Benaming : SR350HB - Uitvalbeveiliging			Nummer: 1 Van : 1
			Formaat: A3

afwerkkap deling / Cover cap division / teilung der Schienenverblendungskappe

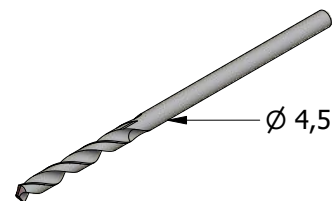
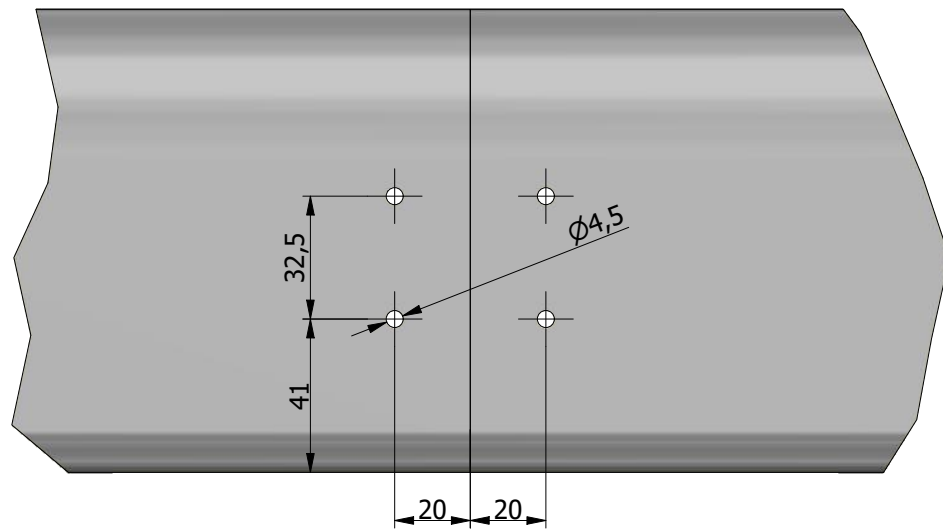
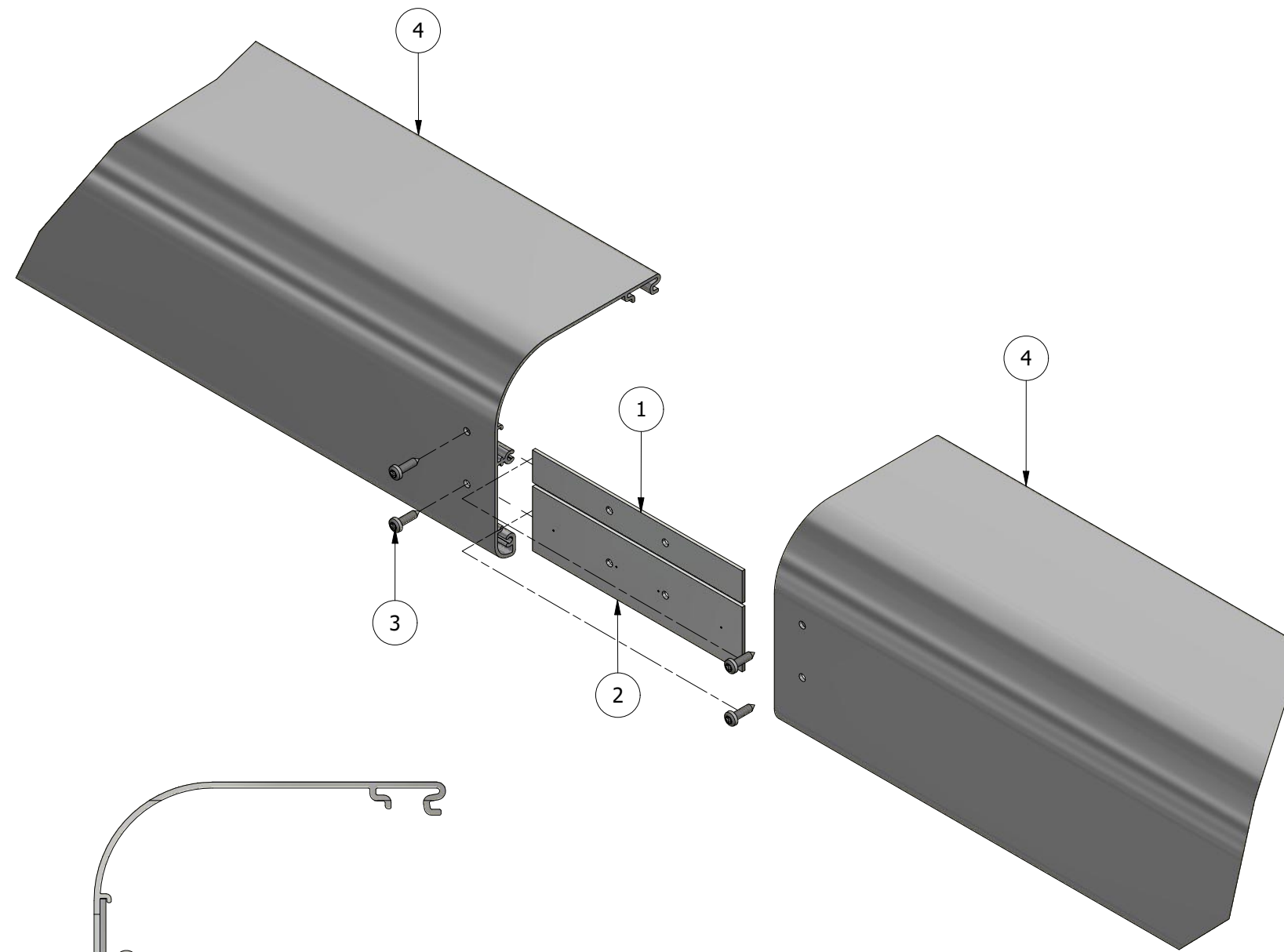

Pos	Aantal	Omschrijving	Artikelnummer
4	2	SRA250 afwerkk.HB ano L= 3350mm	A-73633-00
3	4	zelfborende schroef 4.2 x 16mm a2 assy AW20	A-66632-00
2	1	SRA afwerkkap koppelplaatje 40x150mm	A-82554-00
1	1	SRA250 afwerkkap koppelplaatje 20x150mm	A-82553-00

Ruwheid NEN 3634	Maattolerantie NEN-ISO-406	Getekend : AGR	Vorm en plaatstol. NEN-ISO-1101
Amerikaanse projectie 	Schaal : Maateenheid: mm	Datum : 5-6-2019	Tekeningnummer : SRA350-MON-11010
Benaming : SR350HB - afwerkkap met deling			Nummer: 1 Van : 1
			Formaat: A3

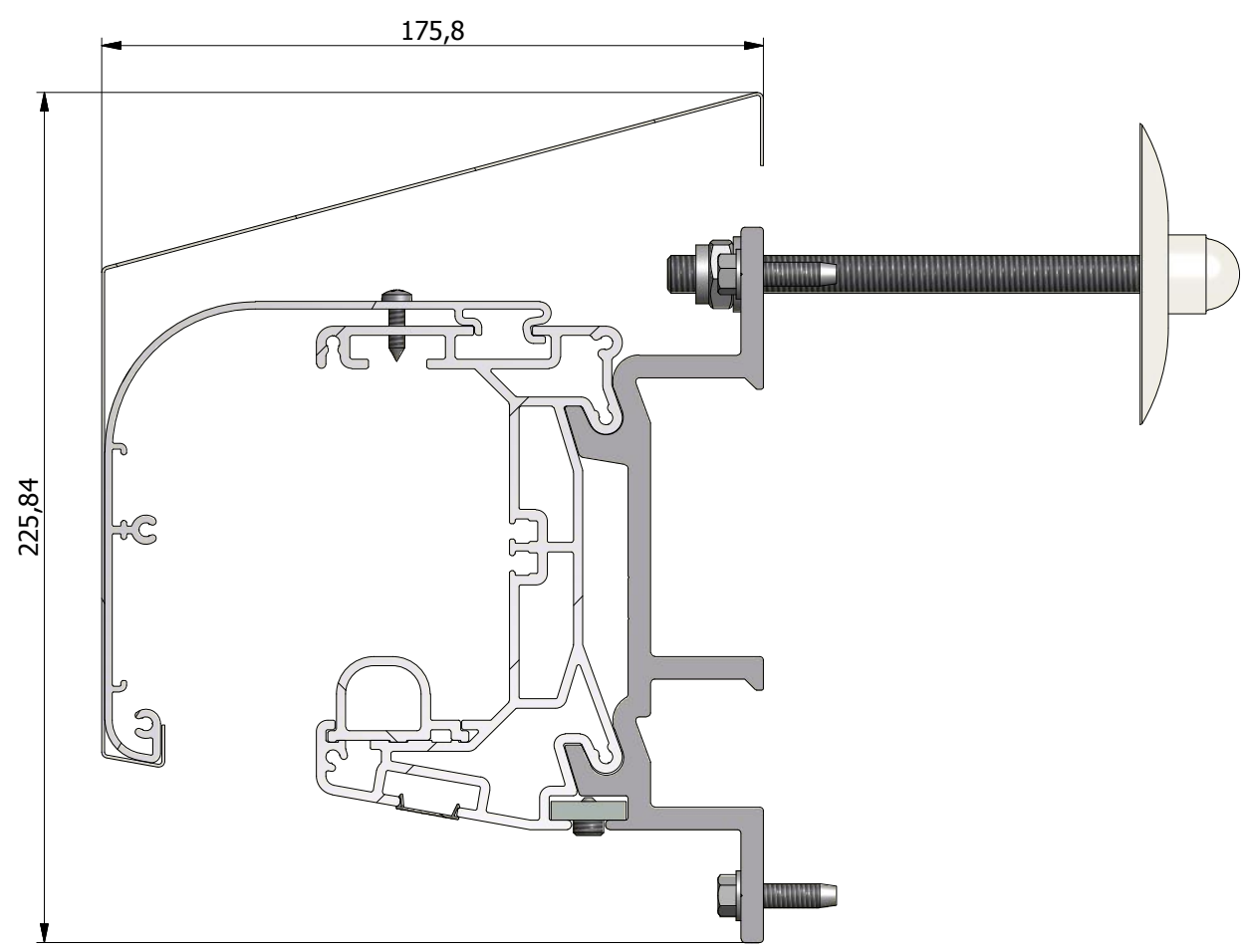
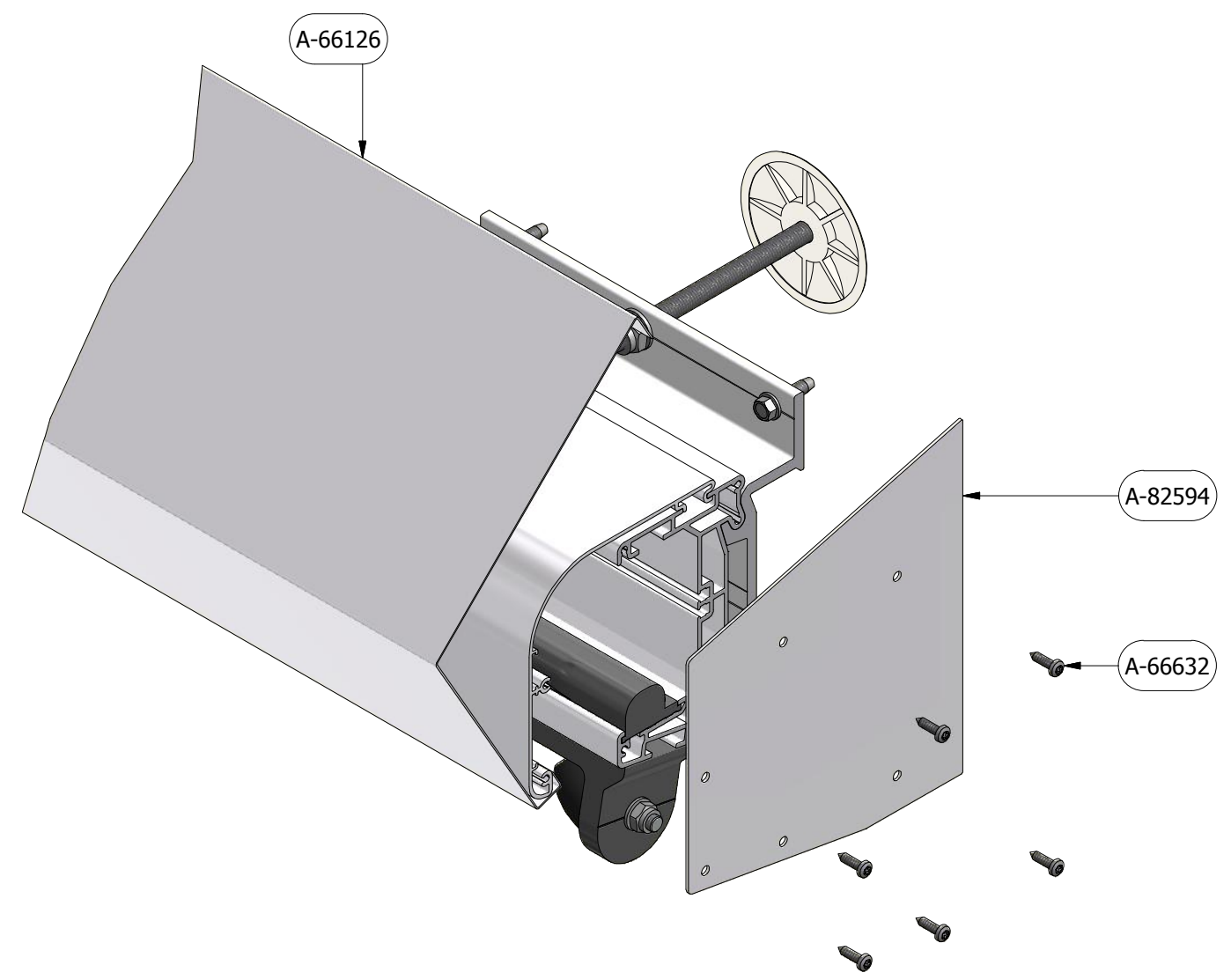
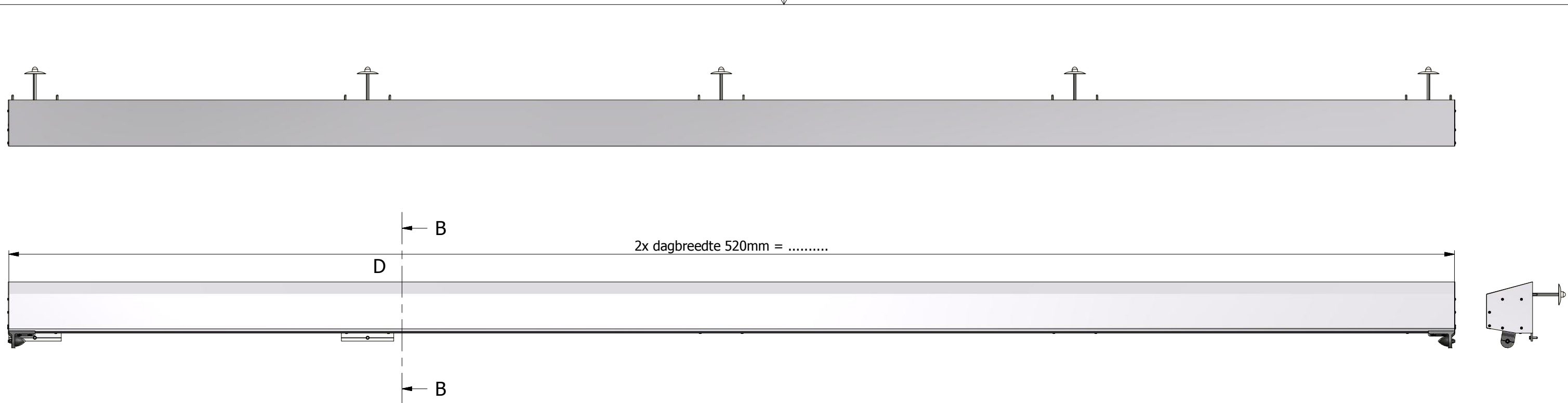

Ruwheid NEN 3634	Maattolerantie NEN-ISO-406		Vorm en plaatstol. NEN-ISO-1101
Amerikaanse projectie 	Schaal : Maateenheid: mm	Getekend : AGR Datum : 28-6-2012	Tekeningnummer : SRALU-MON-30003
Benaming : SRA250 HB - rvs kap sluitzijde			Nummer: 1 Van : 1
			Formaat: A3